

GE8025 Series

80x80x25mm (3.1"x3.1"x1")



Fan Frame: Thermoplastic PBT UL 94V-0
 Fan Impeller: Thermoplastic PBT UL 94V-0
 Bearing system: Ball bearing and Sleeve bearing available
 Operation Temp: -30~70°C (Ball bearing)
 -10~55°C (Sleeve bearing)
 Service Life: 70000hours @40°C (Ball bearing)
 30000hours @40°C (Sleeve bearing)
 Weight: 72g

Engineering Drawing (mm)

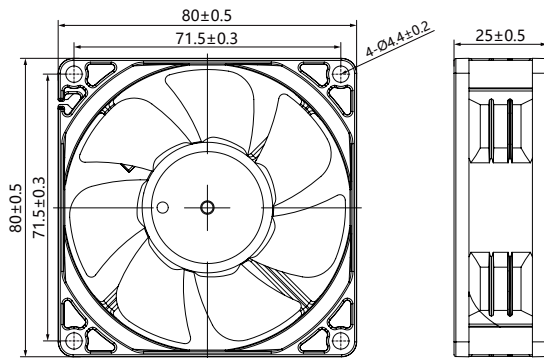

Air Performance

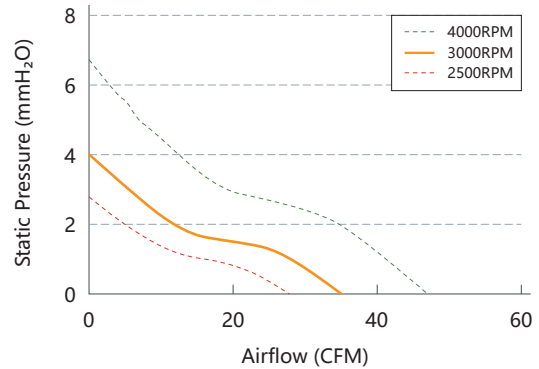

Available Functions

Motor protection

RP	SS	AS	CL	OVP
<input type="radio"/>	<input type="radio"/>	<input checked="" type="radio"/>	<input type="radio"/>	<input type="radio"/>

Signal output

FG	RD	RDB	LD
<input type="radio"/>	<input type="radio"/>	<input type="radio"/>	<input type="radio"/>

Speed control mode

PWM	TC	VC	CC	CS
<input type="radio"/>	<input type="radio"/>	<input type="radio"/>	<input type="radio"/>	<input type="radio"/>

Specifications

Model	Voltage	Voltage Range	Freq.	Power	Speed	Maximum Air Flow	Maximum Air Pressure	Noise		
No.	VAC	VAC	Hz	W	RPM	m ³ /min	CFM	mmH ₂ O	INH ₂ O	dB(A)
GE8025M1/2	110/220	100~240	50/60	3	3000	1.04	36.63	4	0.16	35.2