

# GRD7530 Series

75x75x30mm (3"x3"x1.2")



Fan Frame: Thermoplastic PBT UL 94V-0  
 Fan Impeller: Thermoplastic PBT UL 94V-0  
 Bearing system: Ball bearing and Sleeve bearing available  
 Operation Temp: -30~70°C (Ball bearing)  
 -10~55°C (Sleeve bearing)  
 Service Life: 70000hours @40°C (Ball bearing)  
 30000hours @40°C (Sleeve bearing)  
 Weight: 78.5g

## Engineering Drawing (mm)

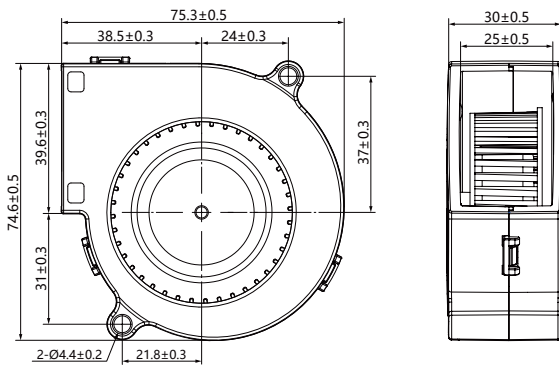

## Air Performance

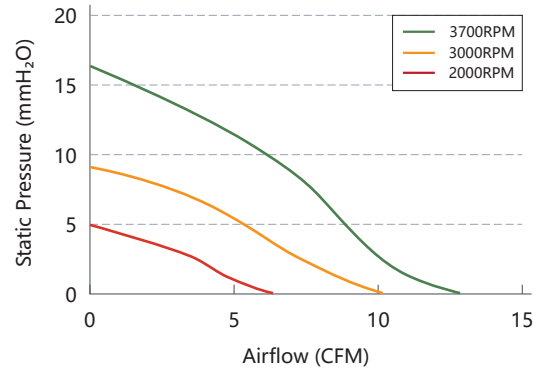

## Available Functions

### Motor protection

RP SS AS CL OVP

### Signal output

FG RD RDB LD

### Speed control mode

PWM TC VC CC CS

## Specifications

Model	Voltage	Voltage Range	Current	Power	Speed	Maximum Air Flow	Maximum Air Pressure	Noise		
No.	VDC	VDC	A	W	RPM	m <sup>3</sup> /min	CFM	mmH <sub>2</sub> O	INH <sub>2</sub> O	dB(A)
GRD7530L12	12	6.0 to 13.5	0.12	1.44	2000	0.18	6.31	5.04	0.2	32.2
GRD7530L24	24	18 to 26.5	0.08	1.92						
GRD7530M12	12	6.0 to 13.5	0.22	2.64						
GRD7530M24	24	18 to 26.5	0.14	3.36	3000	0.29	10.35	8.96	0.35	41.9
GRD7530M48	48	36 to 54	0.07	3.36						
GRD7530H24	24	18 to 26.5	0.3	7.2	3700	0.36	12.66	16.28	0.64	46.1
GRD7530H48	48	36 to 54	0.11	5.28						