

GE22060 Series

Ø220x60mm (Ø8.7"x2.4")



Fan Frame: Aluminum ADC-12, Painted Black
 Fan Impeller: Thermoplastic PBT UL 94V-0
 Bearing system: Ball bearing
 Operation Temp: -30~70°C
 Service Life: 70000hours @40°C
 Weight: 1038g

Engineering Drawing (mm)

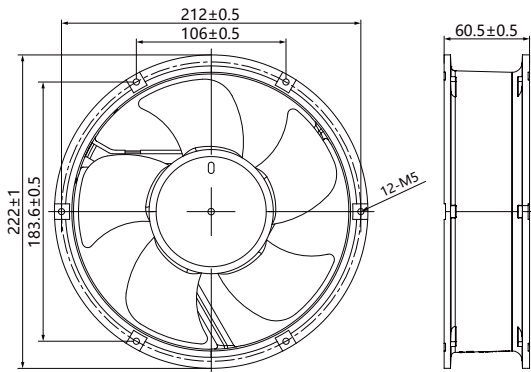

Air Performance

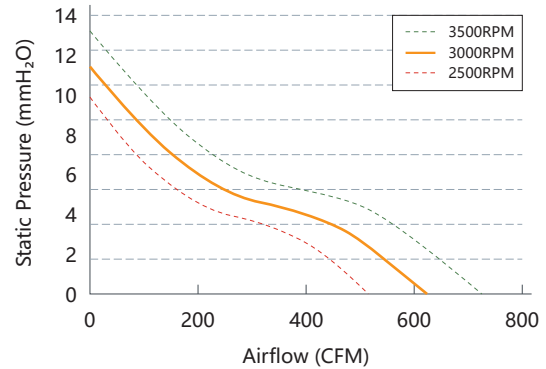

Available Functions

Motor protection

RP	SS	AS	CL	OVP
<input type="radio"/>	<input type="radio"/>	<input checked="" type="radio"/>	<input type="radio"/>	<input type="radio"/>

Signal output

FG	RD	RDB	LD
<input checked="" type="radio"/>	<input checked="" type="radio"/>	<input type="radio"/>	<input type="radio"/>

Speed control mode

PWM	TC	VC	CC	CS
<input checked="" type="radio"/>	<input type="radio"/>	<input type="radio"/>	<input type="radio"/>	<input type="radio"/>

Specifications

Model	Voltage	Voltage Range	Freq.	Power	Speed	Maximum Air Flow	Maximum Air Pressure	Noise		
No.	VAC	VAC	Hz	W	RPM	m ³ /min	CFM	mmH ₂ O	INH ₂ O	dB(A)
GE22060M110	110	100/125	50/60	28	3000	17.49	616.4	11.08	0.44	65.8
GE22060M220	220	200/240	50/60	28						