

GD8025 Series

80x80x25mm (3.1"x3.1"x1")



Fan Frame: Thermoplastic PBT UL 94V-0
 Fan Impeller: Thermoplastic PBT UL 94V-0
 Bearing system: Ball bearing and Sleeve bearing available
 Operation Temp: -30~70°C (Ball bearing)
 -10~55°C (Sleeve bearing)
 Service Life: 70000hours @40°C (Ball bearing)
 30000hours @40°C (Sleeve bearing)
 Weight: 72g
 Option: Customized IP67/IP68 protection level

Engineering Drawing (mm)

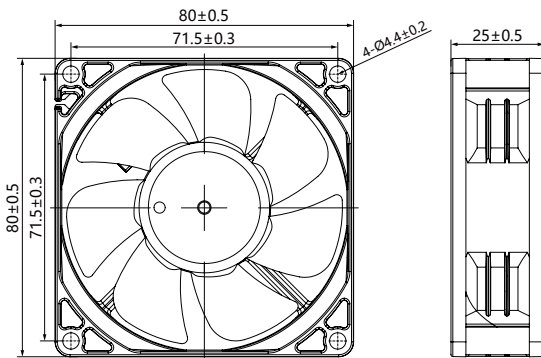

Air Performance

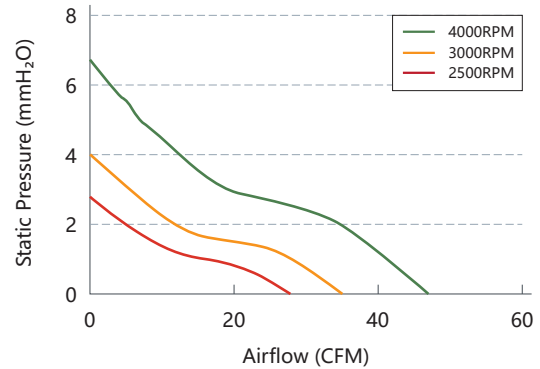

Available Functions

Motor protection

RP	SS	AS	CL	OVP
●	●	●	○	○

Signal output

FG	RD	RDB	LD
●	●	○	○

Speed control mode

PWM	TC	VC	CC	CS
●	○	○	○	○

Specifications

Model	Voltage	Voltage Range	Current	Power	Speed	Maximum Air Flow	Maximum Air Pressure	Noise		
No.	VDC	VDC	A	W	RPM	m ³ /min	CFM	mmH ₂ O	INH ₂ O	dB(A)
GD8025L12	12	6.0 to 13.5	0.15	1.8	2500	0.82	28.91	1.843	0.07	28.3
GD8025L24	24	18 to 26.5	0.08	1.92	3000	1.04	36.63	4	0.16	35.2
GD8025M12	12	6.0 to 13.5	0.3	3.6	4000	1.38	44.2	6.72	0.26	42.9
GD8025M24	24	18 to 26.5	0.15	3.6	4800	1.8	63.5	9.0	0.35	48.0
GD8025H12	12	6.0 to 13.5	0.45	5.4	4000	1.38	44.2	6.72	0.26	42.9
GD8025H24	24	18 to 26.5	0.25	6	4800	1.8	63.5	9.0	0.35	48.0
GD8025H48	48	36 to 54	0.1	4.8	4800	1.8	63.5	9.0	0.35	48.0

DC Axial Fan - GD Series
DC Radial Fan - GRD Series
EC Axial Fan - GE Series