

GD8015 Series

80x80x15mm (3.1"x3.1"x0.6")



Fan Frame: Thermoplastic PBT UL 94V-0
 Fan Impeller: Thermoplastic PBT UL 94V-0
 Bearing system: Ball bearing and Sleeve bearing available
 Operation Temp: -30~70°C (Ball bearing)
 -10~55°C (Sleeve bearing)
 Service Life: 70000hours @40°C (Ball bearing)
 30000hours @40°C (Sleeve bearing)
 Weight: 48.8g

Engineering Drawing (mm)

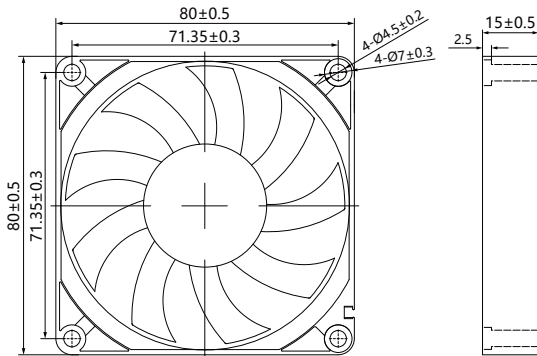

Air Performance

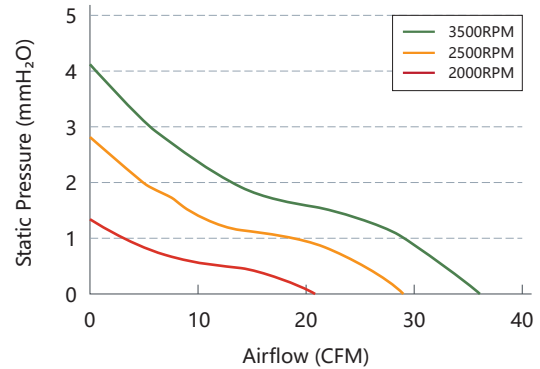

Available Functions

Motor protection

RP	SS	AS	CL	OVP
●	●	●	○	○

Signal output

FG	RD	RDB	LD
●	●	○	○

Speed control mode

PWM	TC	VC	CC	CS
●	○	○	○	○

Specifications

Model	Voltage	Voltage Range	Current	Power	Speed	Maximum Air Flow	Maximum Air Pressure	Noise		
No.	VDC	VDC	A	W	RPM	m ³ /min	CFM	mmH ₂ O	INH ₂ O	dB(A)
GD8015L05	5	3.6 to 6.8	0.24	1.2	2000	0.61	21.26	1.29	0.05	26.6
GD8015M12	12	6.0 to 13.5	0.13	1.56	2500	0.83	29.51	2.77	0.11	29.2
GD8015M24	24	18 to 26.5	0.08	1.92	3500	1.04	36.64	4.05	0.16	35.6

DC Axial Fan - GD Series
DC Radial Fan - GRD Series
EC Axial Fan - GE Series