

# GD5010 Series

50x50x10mm (2"x2"x0.4")



Fan Frame: Thermoplastic PBT UL 94V-0  
 Fan Impeller: Thermoplastic PBT UL 94V-0  
 Bearing system: Ball bearing and Sleeve bearing available  
 Operation Temp: -30~70°C (Ball bearing)  
 -10~55°C (Sleeve bearing)  
 Service Life: 70000hours @40°C (Ball bearing)  
 30000hours @40°C (Sleeve bearing)  
 Weight: 16.9g

## Engineering Drawing (mm)

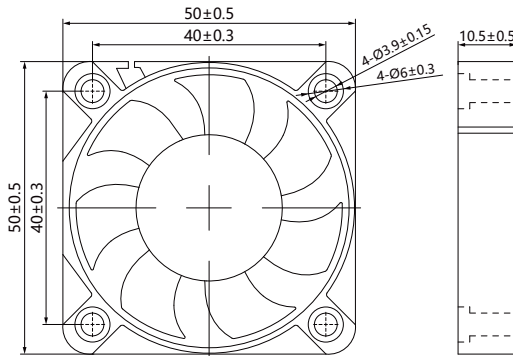

## Air Performance

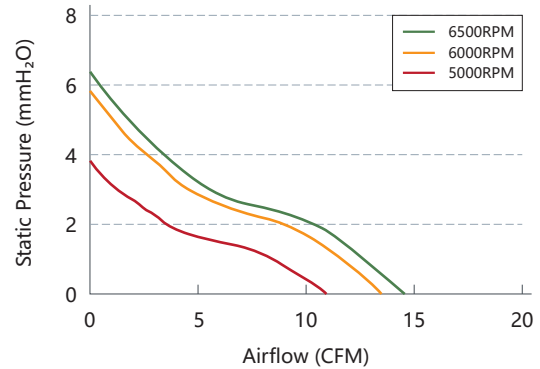

## Available Functions

### Motor protection

|    |    |    |    |     |
|----|----|----|----|-----|
| RP | SS | AS | CL | OVP |
| ●  | ●  | ●  | ○  | ○   |

### Signal output

|    |    |     |    |
|----|----|-----|----|
| FG | RD | RDB | LD |
| ●  | ●  | ○   | ○  |

### Speed control mode

|     |    |    |    |    |
|-----|----|----|----|----|
| PWM | TC | VC | CC | CS |
| ●   | ○  | ○  | ○  | ○  |

## Specifications

| Model     | Voltage | Voltage Range | Current | Power | Speed | Maximum Air Flow    | Maximum Air Pressure | Noise              |                    |       |
|-----------|---------|---------------|---------|-------|-------|---------------------|----------------------|--------------------|--------------------|-------|
| No.       | VDC     | VDC           | A       | W     | RPM   | m <sup>3</sup> /min | CFM                  | mmH <sub>2</sub> O | INH <sub>2</sub> O | dB(A) |
| GD5010L05 | 5       | 3.6 to 6.8    | 0.17    | 0.85  | 5000  | 0.32                | 11.23                | 3.8                | 0.15               | 28.5  |
| GD5010L12 | 12      | 6.0 to 13.5   | 0.1     | 1.2   | 6000  | 0.38                | 13.61                | 5.89               | 0.23               | 32.6  |
| GD5010M05 | 5       | 3.6 to 6.8    | 0.23    | 1.15  | 6500  | 0.42                | 14.74                | 6.38               | 0.25               | 34.2  |
| GD5010M12 | 12      | 6.0 to 13.5   | 0.14    | 1.68  | 6500  | 0.42                | 14.74                | 6.38               | 0.25               | 34.2  |
| GD5010M24 | 24      | 18 to 26.5    | 0.08    | 1.92  | 6500  | 0.42                | 14.74                | 6.38               | 0.25               | 34.2  |
| GD5010H12 | 12      | 6.0 to 13.5   | 0.22    | 2.64  | 6500  | 0.42                | 14.74                | 6.38               | 0.25               | 34.2  |
| GD5010H24 | 24      | 18 to 26.5    | 0.12    | 2.88  | 6500  | 0.42                | 14.74                | 6.38               | 0.25               | 34.2  |

DC Axial Fan - GD Series  
DC Radial Fan - GRD Series  
EC Axial Fan - GE Series