

GN220F

Ø220x60mm (8.7"x2.4")



Fan Frame:	Die-cast Aluminum(Black or Silver coating)
Fan Impeller:	Plastic
Operation Temp.:	-30~60°C
Operation Voltage Range:	110V(±10%); 220V(±10%)
Dielectric Strength:	5mA Max.at 1500V for 1 min
Safety:	Impedance Protected
Termination:	Lead Wire; Pin
Weight:	1500g
Protection Class:	IP44
Insulation:	Class A
Option:	Customized Dual Voltage 110V/220V

Specifications

Model	Bearing	Blades	Voltage	Freq.	Current	Power	Speed	Noise	Max. Air Flow	Pressure	
No.			VAC	Hz	A	W	RPM	dB(A)	m³/h	CFM	mmH ₂ O
GN220F1	Ball	5	100/125	50/60	0.58	45/42	2600/2700	63/65	544/561	320/330	5.34/2.1
GN220F2	Ball	5	200/240	50/60	0.35/0.32	45/42	2600/2700	63/65	544/561	320/330	5.34/2.1
GN220F3	Ball	5	360/400	50/60	0.2/18	45/42	2600/2700	63/65	544/561	320/330	5.34/2.1

Engineering Drawing (mm)

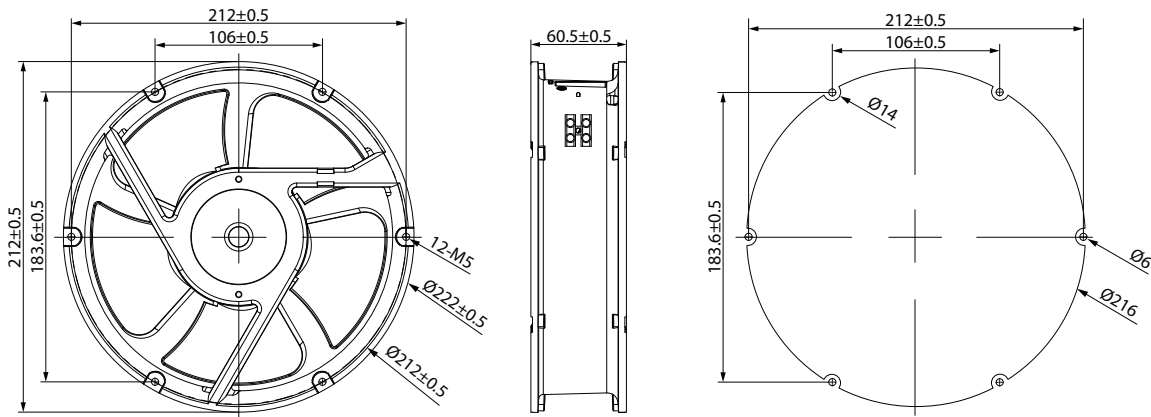

Air Performance

